

EXPLODED VIEW & PARTS LISTING

Model: DP-40BST-HD (XDP)



Part#: 854360 (FLG)

Air Operated Double Diaphragm Pump

Part#: 854367 (NPT)

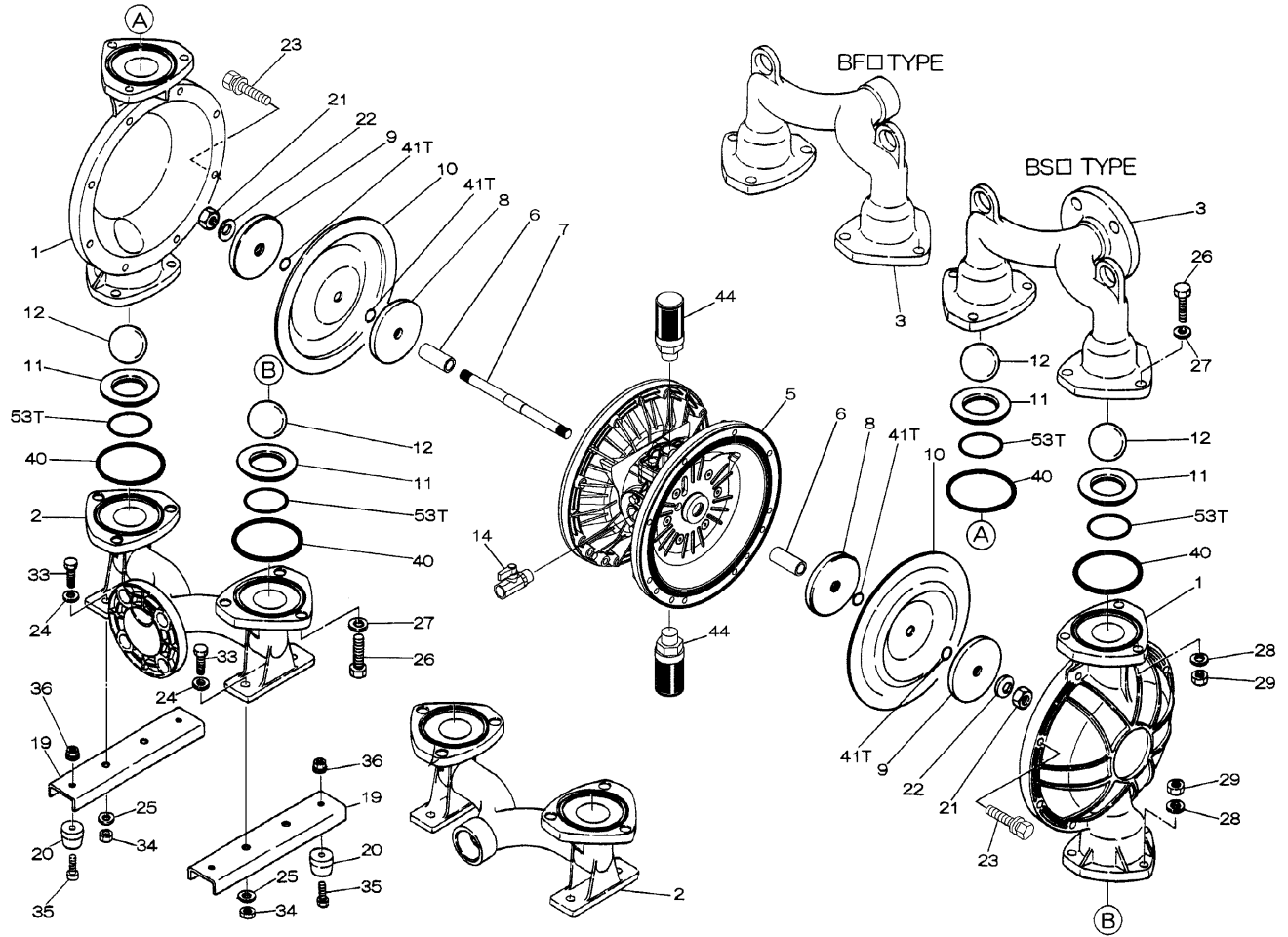

**804850 Center Body Assembly**

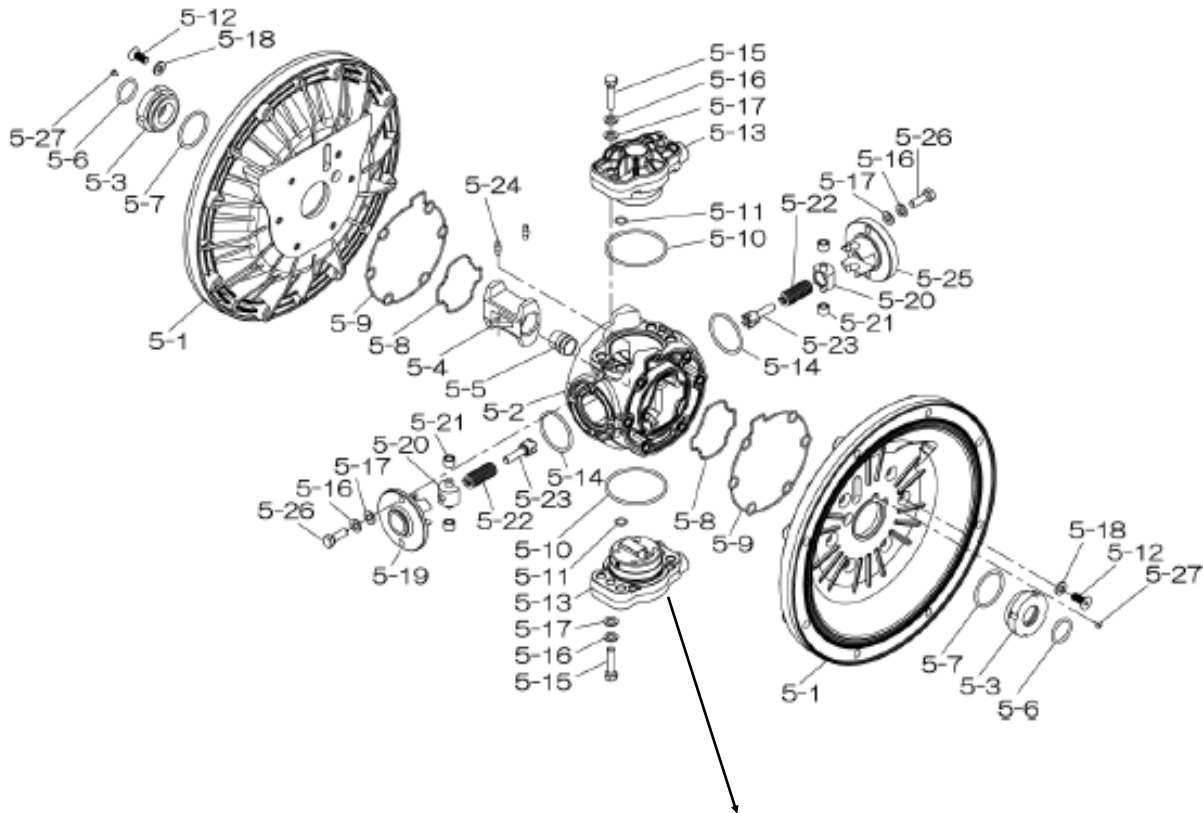

**804784 Valve Body Assembly**

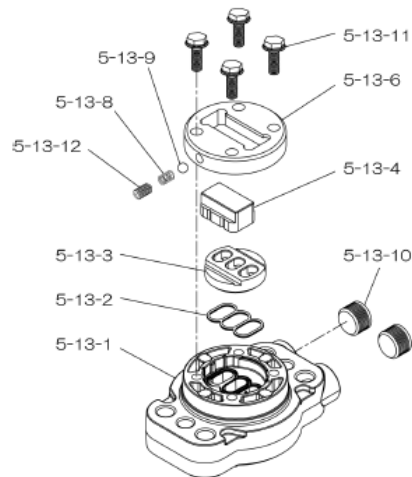

REF. No.	PART No.	DESCRIPTION	QTY.	REORDER
1	712931	OUT CHAMBER 40SS	2	
2	712599	IN MANIFOLD 40SS FLG	1	
2	712601	IN MANIFOLD 40SS NPT	1	
3	712598	OUT MANIFOLD 40SS FLG	1	
3	712600	OUT MANIFOLD 40SS NPT	1	
5	804850	CENTER BODY ASSY DP-40T-HD	1	
5-1	716215	AIR CHAMBER	2	
5-2	716256	BODY	1	
5-3	773095	THROAT BEARING	2	
5-4	716214	SHUTTLE (CS)	1	
5-5	773047	CENTER ROD GUIDE	1	
5-6	640023	O RING 24.6MM X 3.6MM	2	
5-7	640133	O RING	2	
5-8	773040	GASKET	2	
5-9	773041	GASKET	2	
5-10	640138	O RING (64.5X3.0MM)	2	
5-11	640007	O RING 9.5MM X 2.0MM	8	
5-12	683812	M8X1.25X20 FLAT SOCKET	12	
5-13	804784	VALVE BODY ASSY	2	
5-13-1	716244	VALVE BODY	1	
5-13-2	773042	GASKET	1	
5-13-3	716246	SEAT (CS)	1	
5-13-4	773425	BLOCK	1	
5-13-6	773426	GUIDE PLATE	1	
5-13-8	706612	SPRING INK	1	
5-13-9	686271	BALL	1	
5-13-10	772934	PLUG 20/25-PP	2	
5-13-11	602300	TAPPING BOLT	4	
5-13-12	610025	HEX. SOCKET HEAD SCREW	1	
5-14	640134	O RING	2	
5-15	611153	BOLT	4	
5-16	631420	SPRING WASHER M8 ZINC	8	
5-17	631013	WASHER FLAT M8 ZINC DI	8	
5-18	684987	WASHER	12	
5-19	716249	RETAINER	1	
5-20	713620	SPRING GUIDE	2	
5-21	773067	BUSH	4	
5-22	686303	SPRING	2	
5-23	714446	TRIP ARM	2	
5-24	700231	PIN	2	
5-25	716216	RETAINER	1	
5-26	611149	BOLT	4	
5-27	686337	TAPPING SCREW	2	
6	716399	CENTER BUSH	2	

REF. No.	PART No.	DESCRIPTION	QTY.	REORDER
7	716404	CENTER ROD(H4050)	1	
8	707817	CENTER DISK 40T INNER	2	
9	707818	CENTER DISK 40SS-T	2	
10	770814	DIAPHRAGM (PTFE) 40	2	
11	711908	VALVE SEAT 40SS	4	
12	770692	BALL 40T PTFE	4	
14	684321	BALL VALVE 1/2	1	
16	684339	BUSHING	1	
19	711911	BASE	2	
20	771402	FOOT RUBBER	4	
21	706128	NUT SS	2	
22	682740	WASHER	2	
23	686162	BOLT	16	
24	631014	WASHER FLAT	4	
25	631917	WAVE WASHER	20	
26	611203	BOLT	12	
27	631015	WASHER FLAT	12	
28	631918	WAVE WASHER	12	
29	627014	NUT	12	
33	611175	BOLT	4	
34	627013	NUT	4	
35	611149	BOLT	4	
36	682276	NUT W/ FLANGE	4	
40	643065	O RING	4	
41T	643015	O RING	4	
44	804697	MUFFLER	2	
53T	643136	O RING	4	
KIT	K40-MT	LIQUID SIDE KIT		
KIT	K45-AM-DP-HD	AIR MOTOR		

Torque Requirements:

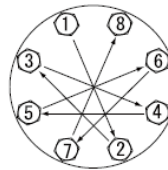

Tightening torque for center rod and out chambers.

Center Rod 43 ft-lbf {60 N-m}  
 Out Chambers 29 ft-lbf {40 N-m}

Tightening torque for manifold retainer bolts.

BST 18 ft-lbf {25 N-m}

General Tools:

- Socket wrench - 24mm
- Hexagonal box wrench - 5mm, 6mm
- Open-end wrenches - 19mm, 24mm
- Phillips head screw driver

Special Tools:

- Socket (804129) for a guide to remove the throat bearing (sold separately)

Miscellaneous:

- Assembly Oil - Turbine oil none additional class 1 (equivalent to ISA VGA32 grade)
- Nuts - M16 x 1.5
- Thread locker
- Urea grease grade (NLGI) No. 2, Shell Alvania Grease S1

Customer Notes

Model #: \_\_\_\_\_  
 Description: \_\_\_\_\_  
 Serial #: \_\_\_\_\_  
 Date Installed: \_\_\_\_\_  
 Department Location: \_\_\_\_\_  
 Tag/Project: \_\_\_\_\_